

# ◆ DMX512 Signal Amplifier Manual



Note: A 21 cm cable is typically provided on both sides of the standard amplifier for wiring purposes.

## I. Parameter characteristics:

- Compatible with and supports the DMX512 (1990) signal protocol.
- Adaptive decoding technology with up to 12-bit precision, capable of adaptive decoding for DMX512 signals transmitted at rates ranging from 200K to 800Kbps.
- Unidirectional signal transmission facilitates usage differentiation and effectively prevents the impact of lamp circuit short circuits on control lines.
- Wide input voltage range, stable operation at DC12~35V.
- Suitable for applications requiring 485 signal cascading and multiple amplifier series connections.
  - Optical signals are immune to electromagnetic interference, ensuring stable and reliable operation.
  - The optical coupler exhibits fast response speed and high transmission efficiency. The bus input/output provides superior signal protection.

## II. Technical Parameters:

<b>operate mode :</b>	mode of connection
<b>Parameter characteristics:</b>	Signal amplification, strong electrical isolation
<b>working temperature :</b>	-20°C--75°C
<b>working voltage :</b>	DC12—24V
<b>maximum power :</b>	0.5W

<b>weight :</b>	Net weight: 0.5 kg
<b>size :</b>	Local dimensions: 12×5×3.5 cm, with side line lengths of 21 cm

**3. Port amplifier wiring diagram:**



**Option 1:**

5-wire DMX512 lighting fixture

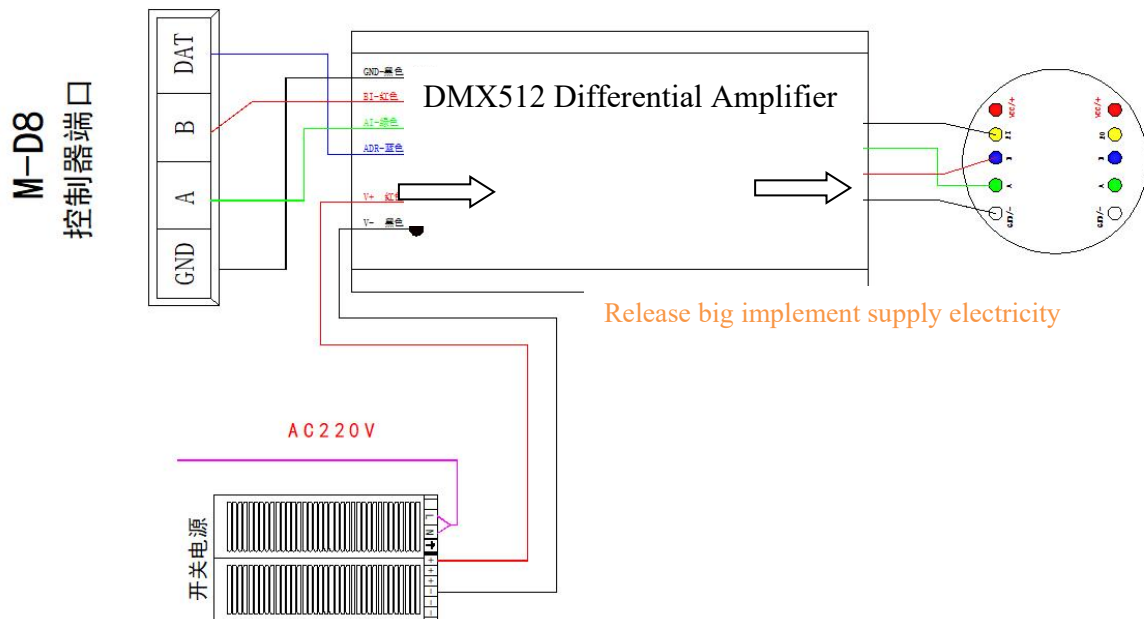

Option  
2,

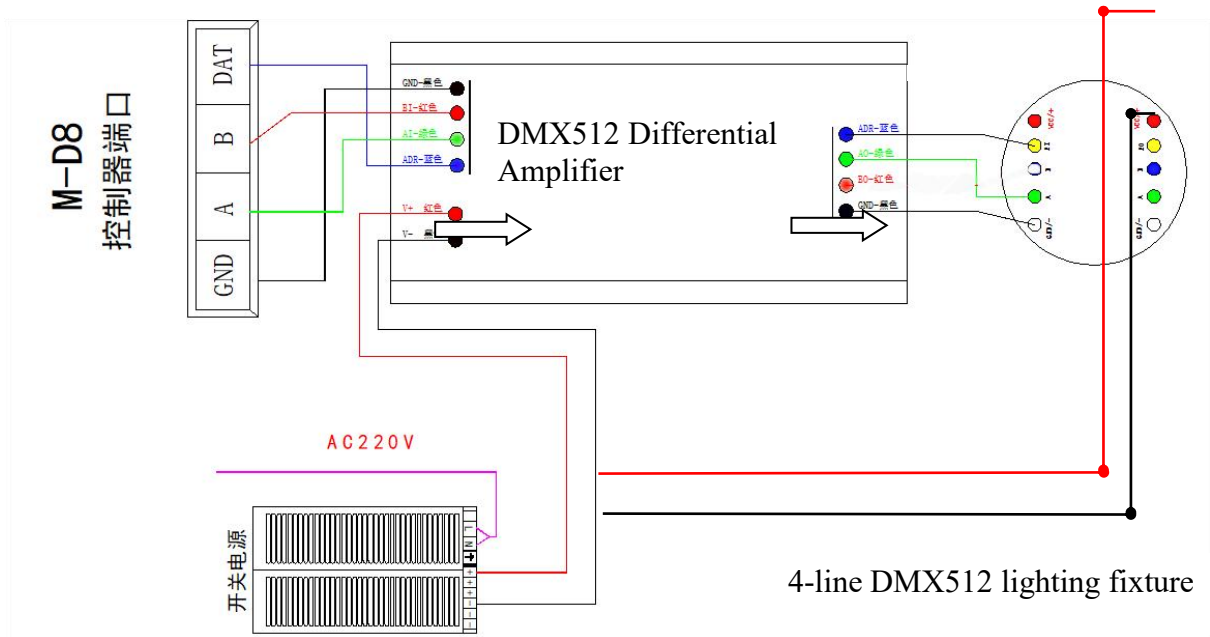

pay attention to :

- 1、 The controller connects to a 5-pin 512 LED driver, with both A and B lines required for connection. Special chips do not require the write code line to be connected. For example, the UCS512C series chips only require connections to A, B, and GND; the write code line on the controller is not connected, but the LEDs must still be interfaced with each other.
- 2、 The controller connects to a 4-wire 512 LED driver. Since the driver has only one data line, it requires only GND and A lines, with B line left unconnected. The code writing line follows the same principle as described above.
- 3、 All lines from the controller to the amplifier must be properly connected, as shown in the two diagrams above.

#### IV. Application

Option 1: Amplifier: Place between the controller and the lamp

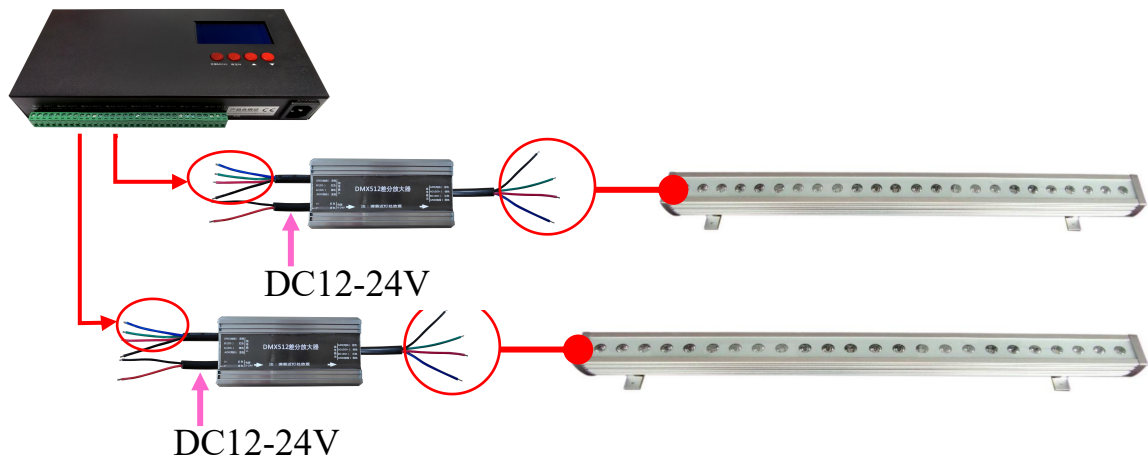

Plan 2:

Amplifier: Place between lamps

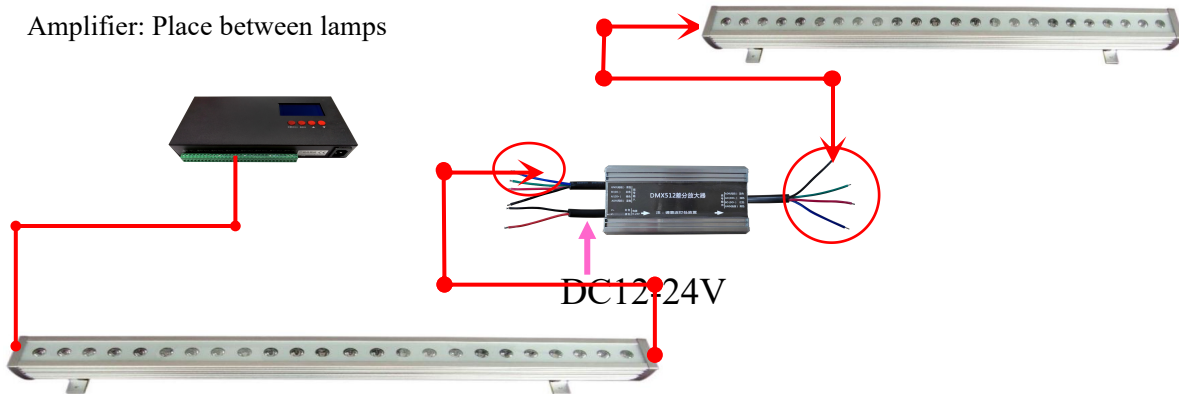

1. The maximum transmission distance for conventional four-wire 512 systems is 100 meters, which can be extended by an additional 50 meters with the addition of a differential amplifier.
2. The maximum transmission distance for standard 512-line systems is 150 meters, which can be extended by an additional 50 meters with the addition of a differential amplifier.
3. Ensure proper color differentiation in wiring, and the amplifier may be installed between lamps.
4. Extension cables shall uniformly adopt Category 5e shielded network cables.